

# **ECS Series Counting Scale**

## **User Manual**

# Contents

SECTION 1 INTRODUCTION	... ..2
SECTION 2 SPECIFICATIONS	... ..3
SECTION 3 INSTALLATION	... ..4
SECTION 4 KEY DESCRIPTIONS	... ..5
SECTION 5 DISPLAYS	... ..6
5.1 Display map	... ..6
5.2 Weight display	... ..6
5.3 Unit weight display	... ..6
5.4 Quantity display	... ..7
SECTION 6 BASIC OPERATION	... ..8
6.1 Zeroing the display	... ..8
6.2 Taring	... ..8
6.2.1 normal tare	... ..8
6.2.2 pretare	... ..9
SECTION 7 PARTS COUNTING	... ..10
7.1 Setting unit weight	... ..10
7.2 Entering a known weight	... ..10
7.3 Parts counting	... ..11
7.4 Automatic part weight update	... ..11
7.5 Count preset or check-weighing	... ..11
7.6 Manually accumulated total	... ..12
7.7 Automatic accumulated totals	... ..12
SECTION 8 BATTERY OPERATION	... ..13
SECTION 9 RS-232 OUTPUT	... ..14
SECTION 10 PARAMETERS	... ..15
SECTION 11 CALIBRATION	... ..16
11.1 Linear calibrate	... ..16
11.2 Normal calibrate	... ..16

## SECTION 1

# INTRODUCTION

The ECS series of scales provides an accurate, fast and versatile series of counting and check-weighing scales.

There are 4 models in this series, with capacities up to 30 kg.

They all have stainless steel weighing platforms on an ABS base assembly. All the keypads are sealed, color coded membrane switches and the displays are large easy to read liquid crystal type displays (LCD). The LCD's are supplied with a backlight.

All units include automatic zero tracking, audible alarm for pre-set weights, automatic tare, pre-set tare and an accumulation facility that allows the count to be stored and recalled as an accumulated total.

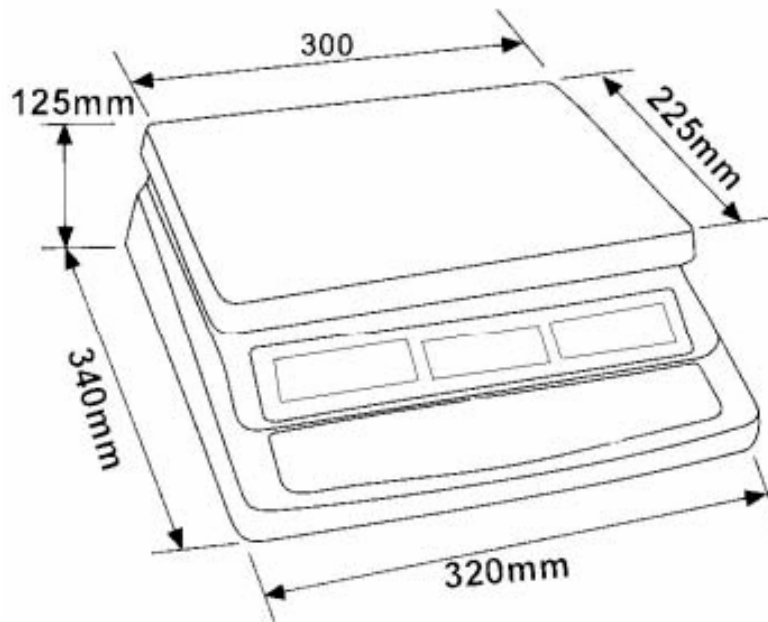

# SECTION 2

## SPECIFICATIONS

### 2.1 ECS series

<b>ECS SERIES</b>				
<b>Model #</b>	<b>ECS 3000</b>	<b>ECS 6000</b>	<b>ECS 15</b>	<b>ECS 30</b>
Maximum Capacity	3 kg	6 kg	15 kg	30 kg
Readability	0.1 g	0.2 g	0.5 g	1 g
Resolution	1:30.000	1:30.000	1:30.000	1:30.000
Tare Range	-3kg	-6kg	-15kg	-30kg
Minimum Capacity	2 g	4 g	10 g	20 g
Repeatability (Std Dev)	0.1g	0.2g	0.5g	1g
Linearity $\pm$	0.2g	0.4g	1g	2g
Units of Measure	Kg			

## Common Specifications

Interface	RS-232 output optional
Stabilization Time	2 seconds typical
Operating Temperature	0°C - 40° C / 32°F - 104°F
Power Supply (external)	115 / 230 Vac, 50/60Hz, 10 watts
Calibration	Automatic External
Display	3 x 6 digits LCD digital display, 20 mm high
Balance Housing	ABS Plastic, Stainless Steel platform
Pan Size	225 x 300mm / 8.9 x 11.8"
Overall Dimensions (w x d x h)	320 x 340 x 125mm
Gross Weight	3.8kg / 8.4 lb
Applications	General Purpose parts counting Scale
Functions	kilogram weight, parts counting, accumulating memory, preset count with alarm
Other Features and specs	Internal Rechargeable Battery (~70 hours working)

## SECTION 3

# INSTALLATION

### 3.1 GENERAL INSTALLATION

The scales should be sited in a location that will not degrade the accuracy.

Avoid extremes of temperature. Do not place in direct sunlight or near air conditioning vents.

Avoid unsuitable tables. The tables or floor must be rigid and not vibrate. Do not place near vibrating machinery.

Avoid unstable power sources. Do not use near large users of electricity such as welding equipment or large motors.

Avoid high humidity that might cause condensation. Avoid direct contact with water. Do not spray or immerse the scales in water.

Avoid air movement such as from fans or opening doors. Do not place near open windows.

Keep the scales clean.

Do not stack material on the scales when they are not in use.

### 3.2 INSTALLATION of ECS SERIES

The ECS Series comes with a stainless steel platform packed separately. Place the platform in the locating holes on the top cover. Do not press with excessive force as this could damage the load cell inside.

Level the scale by adjusting the four feet. The scale should be adjusted such that the bubble in the spirit level is in the center of the level and the scale is supported by all four feet. If the scale rocks readjust the feet.

Attach the main cable to the connector on the bottom of the scale. The power switch is located on the base near the front of the scale.

## SECTION 4

# KEY DESCRIPTIONS

### 0-9, •

Numeric entry keys, used to manually enter a value for tare weights, unit weight, and sample size.

### CE

Used to clear the unit weight or an erroneous entry.

### Zero

Set the zero point for all subsequent weighing. The display shows zero.

### Tare

Tares the scale. Stores the current weight in memory as a tare value, subtracts the tare value from the weight and shows the results. This is the net weight. Entering a value using the keypad will store that value as the tare value.

### M

Add the current count to the accumulator. Up to 99 values or full capacity of the weight display can be added.

### MR

To recall the accumulator memory.

### Smpl

Used to input the number of items in a sample.

### Unit Wt

Used to enter the weight of a sample manually.

### PST or

To set the upper limit for the number of items counted. When this upper limit is exceeded the scale will sound the beeper.

### Print or

To print the results to a PC or printer using the optional RS-232 interface.

## SECTION 5 DISPLAYS

### 5.1 Display map

The scales have three digital displays. The displays show WEIGHT, UNIT WEIGHT and QUANTITY.

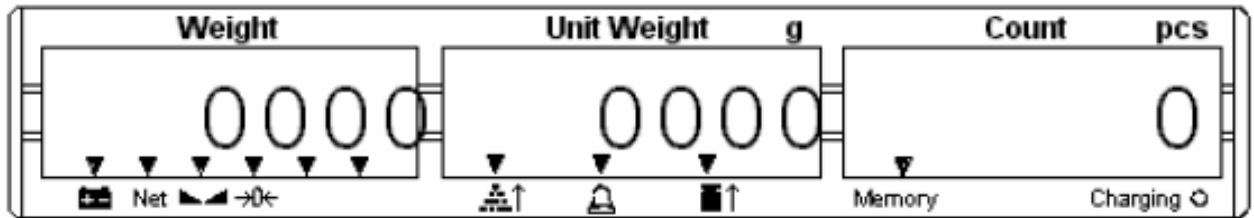



### 5.2 Weight Display

Digit display to indicate the weight on the scale.  
Arrows above symbols will indicate the following:

Low battery, 

Net Weight Display, "Net"

Stability indicator, "Stable" or 

Zero Indicator, "Zero" or 

And in the ECS+ models indications for kilogram "Kg" or Pound "Lb" units.

### 5.3 Unit Weight Display

This display will show the unit weight of a sample. This value is either input by the user or computed by the scale. The unit of measure is grams on all scales.

Indicators will show when the scale has determined that there is an insufficient number of samples to accurately determine the count: "Sample" or  symbol.

When the unit weight is not large enough to determine an accurate count, "U. Weight" or  symbol.

In both cases the scale continues to operate and the indications are to alert the user to a potential problem.

If a preset count has been stored the "Preset" or  symbol will have an arrow above it.

## 5.4 Quantity Display

This display will show the number of items on the scale or the value of the accumulated count. See OPERATION section.

Indicators will show when a value has been entered into memory when the arrow above the "Memory" legend is on.

Just under the quantity display is an LED to indicate the status of battery charging. When the scale is plugged into the mains power the internal battery will be charged. If the LED is green the battery has a full charge. If it is Red the battery is nearly discharged and yellow indicates the battery is being charged.

## SECTION 6

# BASIC OPERATION

### 6.1 Zeroing The Display

You can press the **ZERO** key at any time to set the zero point from which all other weighing and counting is measured, within 4% of power up zero. This will usually only be necessary when the platform is empty. When the zero point is obtained the Weight display will show the indicator for zero.

The scale has an automatic rezeroing function to account for minor drifting or accumulation of material on the platform. However you may need to press **ZERO** to rezero the scale if small amounts of weight are shown when the platform is empty.

### 6.2 Taring

There are two methods to enter a tare value. The first uses the weight on the platform and the second uses a value input by the user.

#### 6.2.1 normal tare

Zero the scale by pressing the **ZERO** key if necessary. The zero indicator will be on.

Place a container on the platform, a value for its weight will be displayed.

Press the **TARE** key to tare the scale. The weight that was displayed is stored as the tare value and that value is subtracted from the display, leaving zero on the display.

The "Net" indicator will be on. As product is added only the weight of the product will be shown. The scale could be tared a second time if another type of product was to be added to the first one. Again only the weight that is added after taring will be displayed.

When the container is removed a negative value will be shown. If the scale was tared just before removing the container this value is the gross weight of the container plus all product that was removed. The zero indicator will also be on because the platform is back to the same condition it was when the **ZERO** key was last pressed.

## 6.2.2 Pretare

This method allows you to enter a value for the tare weight from the keypad. This is useful if all containers are the same or if the container is already full but the net weight is required and the tare weight of the container is known.

Remove all weight from the platform, press the **ZERO** key to zero the display. Enter the value for the Tare weight using the keypad, press **TARE** to store the tare value. The weight will show a negative value equal to the tare.

Place the container on the platform.

The display will then show the weight of the container minus the tare weight. Then when the full container is put on the platform the tare value will be subtracted from the gross weight displaying only the net weight of the contents.

If the value input is not consistent with the increment of the scale the scale will round the tare value to the nearest value possible. For example if a tare value of 10.3g is entered onto the 6Kg/0.5g scale then the display will show -10.5g.

## SECTION 7

# PARTS COUNTING

### 7.1 Setting Unit Weight

In order to do parts counting it is necessary to know the average weight of the items to be counted. This can be done by weighing a known number of the items and letting the scale determine the average unit weight or by manually inputting a known weight using the keypad.

Weighing a sample to determine the Unit Weight

To determine the average weight of the items to be counted it will be necessary to place a known quantity of the items on the scale and then to key in the quantity being weighed.

The scale will then divide the total weight by the number of samples and display the average unit weight.

Zero the scale by pressing the **ZERO** key if necessary. If a container is to be used, place the container on the scale and tare as discussed earlier.

Place a known quantity of items on the scale. After the weight display is stable enter the quantity of items using the numeric keys followed by **SMPL** key. The number of units will be displayed on the "Quantity" display and the computed average weight will be shown on the "Unit Weight" display.

As more items are added to the scale, the weight and the quantity will increase.

If the scale is not stable, the calculation will not be completed. If the weight is below zero, the quantity display will show negative count.

### 7.2 Entering a Known Unit Weight

If the unit weight is already known then it is possible to enter that value using the keypad.

Enter the value of the unit weight using the numeric keys followed by pressing the **UNIT WT** key. The "Unit Weight " display will show the value as it was entered.

The sample is then added to the scale and the weight will be displayed as well as the quantity based upon the unit weight.

### 7.3 Parts Counting

After the unit weight has been determined or entered it is possible to use the scale for parts counting. The scale can be tared to account for package weight as discussed in an earlier section.

After the scale is tared then the items to be counted are added and the "Quantity" display will show the number of items computed using the weight and the unit weight.

It is possible to increase the accuracy of the unit weight at any time during the counting process by entering the count displayed then pressing the **SMPL** key. You must be certain the quantity displayed matches the quantity on the scale before pressing the key. The unit weight will be adjusted based upon a larger sample quantity. This will give greater accuracy when counting larger sample sizes.

### 7.4 Automatic Part Weight Updates

The scales will automatically update the unit weight when a sample equal to less than the sample already on the platform is added. A beep will be heard when the value is updated. It is wise to check the quantity is correct when the unit weight has been updated automatically.

This feature is turned off as soon as the number of items added exceeds the count used as a sample.

### 7.5 Count Preset or Check-weighing

Check-weighing (Count Pre-setting) is a procedure to cause an alarm to sound when the number of items counted on the scale meets or exceeds a number stored in memory by using the **PST** key.

The stored value is entered from the keyboard. Enter the numeric value to be stored using the numeric keys. Then press the **PST** key to store the value.

To clear the value from memory and thereby turn off the check-weighing feature, enter the value "0" into the memory.

## 7.6 Manually Accumulated Total

The values (weight and count) shown on the display can be added to the values in the accumulator by pressing the **M+** key. The "Weight " display will show the total weight, the "Count" display will show the total accumulated count and the "Unit

Weight" display shows the number of times items have been added to the accumulation memory. The values will be displayed for 2 seconds before returning to normal.

The scale must return to zero or a negative number before another sample can be added to the memory.

More product can then be added and the **M+** key pressed again. This can continue for up to 99 entries, or until the capacity weight display is exceeded.

To observe the total stored press the **MR** key. The totals will be displayed for 2 seconds.

To clear the memory press **MR** to recall the totals from memory and then press the **CE** key to clear all values from memory.

## 7.7 Automatic Accumulated Totals

The scale can be set to automatically accumulate totals when a weight is placed on the scale. This eliminates the need to press the **M+** key to store values into memory.

However the **M+** key is still active and can be pressed to store the values immediately. In this case the values will not be stored when the scale returns to zero.

*See the PARAMETERS Section for details of how to enable Automatic Accumulation.*

## SECTION 8

# BATTERY OPERATION

The scales can be operated from the battery if desired. The battery life is approximately 100 hours.

When the battery needs charging the arrow above the low battery symbol under the weight display will turn on. The battery should be charged as soon as the arrow above the symbol is on. The scale will still operate for about 10 hours after which it will automatically switch off to protect the battery.

To charge the battery simply plug into the mains power. The scale does not need to be turned on.

The battery should be charged for 12 hours for full capacity.

Just under the quantity display is an LED to indicate the status of battery charging. When the scale is plugged into the mains power the internal battery will be charged. If the LED is green the battery has a full charge. If it is Red the battery is nearly discharged and yellow indicates the battery is being charged.

As the battery is used it may fail to hold a full charge. If the battery life becomes unacceptable then contact your distributor .

## SECTION 9

# RS-232 OUTPUT

The ECS Series of scales can be ordered with an option RS-232 output.

Specifications:

RS-232 output of weighing data  
 ASCII code  
 4800 Baud  
 8 data bits  
 No Parity

Connector: 25 pin d-subminiature socket  
 Pin 2 Output  
 Pin 3 Input, not used at this time  
 Pin 7 Signal Ground

Data Format  
 Normal Output

GS	1.234 Kg	GS for Gross weight, NT for net weight (with tare value stored)
U.W.	123 g	Kg and g for metric and Lb for Pounds
PCS	10 pcs	
<lf>		Includes 2 line feeds
<lf>		

Data Format  
 Memory Recall Print

*****		
<lf>		Includes 1 line feed
TOTAL		
No.	5	
Wgt	1.234 Kg	
PCS	10 pcs	
<lf>		Includes 1 line feed
*****		

## SECTION 10

# PARAMETERS

To set the parameters it is necessary to enter a secure menu. This is done by entering a password number when requested.

To enter the parameter menus press the **TARE** key during the initial counting of the display after power turned on. The Weight Display will show "PIn" requesting the password number to be entered.

The default password is "0000" but other numbers can be set using the parameter menus.

Press the "**O**" key four times. The display will show "PIn- - - -", Press the **TARE** key. The Parameter menu has 5 functions that can be accessed using the **Unit Wt.** key to cycle through the choices. The Weight Display will show the name of the functions. To enter a function press the **TARE** key. At any time press the **ZERO** key to return to weighing.

Weight Display	Description
F1 CAL	See the calibration section for details
F2 dl	Set the scale increment. Press the <b>Unit Wt.</b> key to cycle through the options. Press <b>TARE</b> to accept the selection.
F3 Cnt	Displays the A/D counts. Press Tare to return to menu.
F4 Au	Press the <b>Unit Wt.</b> key to show the options. Select automatic accumulation (Au ON) when the scale becomes stable, or Manual accumulation (Au OFF), when the user must press the <b>M+</b> key to accumulate data.
F5 AZN	Set the auto zero range, Press the <b>Unit Wt.</b> key to cycle through the options(0.5d, 1d, 2d, 4d). Press <b>TARE</b> to accept the selection.
F6 Pin	Set a new password number. Display will show "P1 " Enter the new password number then press the <b>TARE</b> key. Display will change to "P2 ", Enter the password again and press <b>TARE</b> again. The display will show "donE" to show the new password has been accepted. Record the new password number in a secure place.

# SECTION 11

## CALIBRATION

### 11.1 Linear calibrate

Enter the parameter menus by password "9999"

When the parameter menu show "F1 CAL" press the **TARE** key. The display will then show "unLoAd" to request all weight be removed from the platform.

Press the **TARE** key to set the zero point.

The display will then show the first calibration weight request. Either put this weight on the platform and then press the **TARE** key. The scale should be stable before pressing the **TARE** key to accept a weight. The stability indicator will turn on to show the value is stable. When calibration is finished the scale will come into natural weighing if it was successful.

#### Calibration weights

ECS Series				
Model #	AHC 3000	AHC 6000	AHC 15	AHC 30
Weight 1	Zero	zero	zero	Zero
Weight 2	1000 g	2 kg	5 kg	10 kg
Weight 3	3000 g	6 kg	15 kg	30 kg

### 11.2 Normal calibrate

Enter the parameter menus by your password (default: "0000")

When the parameter menu show "F1 CAL" press the **TARE** key. The display will then show "unLoAd" to request all weight be removed from the platform.

Press the **TARE** key to set the zero point.

Key in the calibration weight you want to use, then put this weight on the platform and then press the **TARE** key. The scale should be stable before pressing the **TARE** key to accept a weight. The stability indicator will turn on to show the value is stable.

When calibration is finished the scale will come into natural weighing if it was successful.

“**ENDEL**” is an internationally reputed brand name in Electronic Weighing Instruments since last 11 years.

Our products are produced in India & Taiwan and supplied & serviced from our India, UAE and Kenya hubs; distributed through a world wide dealer network.

All “**ENDEL**” products are carrying advanced technology, designed by our R & D experts for specific commercial & non-commercial use in Laboratory, Medical, Business and Industrial environments.

Brief summary of “**ENDEL**” product range is...

- Laboratory Balances
- Jewelry Balances
- Pocket Scales
- Gem Scales (Carat Scales)
- Table Top Scales / Super Market Scales
  - Simple Weighing Scales
  - Price Computing Scales
  - Piece Counting Scales
  - Wash Proof/ Water Proof Scales
- Platform Scales
- Deck Scales
- Pallet scales
- Crane Scales
- Hanging (fishing) Scales
- Postal / Parcel Scales
- Bathroom Scales
- Kitchen Scales
- Baby Weighing Scales
- Truck Weighing Scales (Weighbridges)
- Weighing Indicators
- Load Cells
- Accessories
- Customized auto weighing systems

“**ENDEL**” operates on approved quality management system and is certified to ISO 9001 : 2000

Visit our web : <http://www.endeavourweigh.com> for more details

*CONTACT for any further assistance*



## PARAG TRADING CO., LLC

22, Bin Sabt Bldg., P-II Al musalla, P.O. Box # 51687, Bur-Dubai, DUBAI, U A E

Phone : +971-4-3522077 ☐ Fax : +971-4-3522088

Email : [paragtrd@emirates.net.ae](mailto:paragtrd@emirates.net.ae)

© PARAG TRADING CO., LLC - 2004

©Copyright by PARAG TRADING CO., LLC All rights reserved.

No part of this publication may be reprinted or translated in any form or by any means without the prior permission of PARAG TRADING CO., LLC

PARAG TRADING CO., LLC reserves the right to make changes to the technology, features, specifications and design of the equipment without notice.

All information contained within this publication was to the best of our knowledge timely, complete and accurate when issued. However, we are not responsible for misimpressions which may result form the reading of this material.